

About this Manual

We've added this manual to the Agilent website in an effort to help you support your product. This manual is the best copy we could find; it may be incomplete or contain dated information. If we find a more recent copy in the future, we will add it to the Agilent website.

Support for Your Product

Agilent no longer sells or supports this product. Our service centers may be able to perform calibration if no repair parts are needed, but no other support from Agilent is available. You will find any other available product information on the Agilent Test & Measurement website, www.tm.agilent.com.

HP References in this Manual

This manual may contain references to HP or Hewlett-Packard. Please note that Hewlett-Packard's former test and measurement, semiconductor products and chemical analysis businesses are now part of Agilent Technologies. We have made no changes to this manual copy. In other documentation, to reduce potential confusion, the only change to product numbers and names has been in the company name prefix: where a product number/name was HP XXXX the current name/number is now Agilent XXXX. For example, model number HP8648A is now model number Agilent 8648A.

HP 8564E and 8565E Spectrum Analyzers Service Guide Supplement

**Using Performance Tests When an
HP 3335A Source Is Not Available**



Manufacturing Part Number: 08564-srvsup

Printed in USA

October 1999

© Copyright 1999 Hewlett-Packard Company

Notice

The information contained in this document is subject to change without notice.

Hewlett-Packard makes no warranty of any kind with regard to this material, including but not limited to, the implied warranties of merchantability and fitness for a particular purpose. Hewlett-Packard shall not be liable for errors contained herein or for incidental or consequential damages in connection with the furnishing, performance, or use of this material.

Assistance

For any assistance, contact your nearest Hewlett-Packard Sales and Service Office.

General Safety Considerations

WARNING ***Before this instrument is switched on, make sure it has been properly grounded through the protective conductor of the ac power cable to a socket outlet provided with protective earth contact.***

Any interruption of the protective (grounding) conductor, inside or outside the instrument, or disconnection of the protective earth terminal can result in personal injury.

WARNING **There are many points in the instrument which can, if contacted, cause personal injury. Be extremely careful.**

Any adjustments or service procedures that require operation of the instrument with protective covers removed should be performed only by trained service personnel.

CAUTION ***Before this instrument is switched on, make sure its primary power circuitry has been adapted to the voltage of the ac power source.***

Failure to set the ac power input to the correct voltage could cause damage to the instrument when the ac power cable is plugged in.

Contents

1. Using this Adjustment Procedure Supplement	
Introduction	1-2
Implementation Instructions	1-3
2. Test Equipment Required for Automated Adjustments	
Introduction	2-12
3. Manual Adjustment Procedures	
Introduction	3-2
3a. Manual Adjustment Procedures: HP 3335A Source Not Available	
What You'll Find in This Chapter	3a-2
Required Test Equipment	3a-3
4a. IF Amplitude Adjustments	3a-4
5a. DC Log Amplifier Adjustments	3a-9

1 Using this Adjustment Procedure Supplement

Introduction

The HP 3335A Synthesizer Level Generator signal source has become obsolete because parts used in the manufacture of this instrument are no longer available from suppliers. To meet the needs of our customers, HP has created new performance verification tests and adjustment tests that use alternative signal sources.

The calibration and service guides are being revised to add additional procedures that do not use the HP 3335A. The changes include the addition of signal sources required to replace the 3335A, changes to the test equipment setup illustrations, and changes in the steps required to execute the procedures.

Because all of our customers will not need to replace the HP 3335A immediately, we are releasing the changes to the calibration guide and service guides in the form of two manual supplements. HP is making these procedure revisions available at this time in electronic form, only. You can download this manual supplement, and add it to your current manual as needed. You will not be required to replace your manuals just to incorporate these changes. These changes will be incorporated in new manuals shipped in the future.

To add these changes to your existing manuals, refer to [“Implementation Instructions,”](#) on [page 3](#).

Implementation Instructions

Update your service guide by performing the following steps:

- Step 1.** After downloading this supplement, print a hard copy of the entire document.
- Step 2.** Remove page 2-7 and 2-8 from your service guide.
- Step 3.** Insert page 2-7 and 2-8 from the supplement into the service guide.
- Step 4.** Remove page 3-1 through 3-8 from your service guide.
- Step 5.** Insert page 3-1 through 2-8 from the supplement into the service guide.
- Step 6.** Remove the adjustment procedure chapter from the supplement, and insert it into your service guide as [Chapter 3a, "Manual Adjustment Procedures: HP 3335A Source Not Available,"](#) immediately after Chapter 3.

2 Test Equipment Required for Automated Adjustments

Introduction

This chapter contains the table of test equipment that is required for the automated adjustments. This table is to replace table [Table 2-2.](#), “[Test Equipment Required for Automated Adjustments](#)” in Chapter 2, “Adjustment/Diagnostic Software,” of your service guide.

This page intentionally left blank.

This page intentionally left blank.

This page intentionally left blank.

This page intentionally left blank.

This page intentionally left blank.

Table 2-2. Test Equipment Required for Automated Adjustments

Description	HP Model Number
Controller*	HP 9000 model 236 (HP 9836) or HP 9000 model 310 or HP 9000 model 320 or HP 9000 model 350
Synthesizer/level generator	HP E4421B or HP 8663A
Synthesized sweeper [†]	HP 83650A
Spectrum analyzer [‡]	HP 8566B (preferred) or HP 8563E (2nd choice) or HP 8563A or HP 8562A
Power meter	HP 438A
4.2 GHz power sensor	HP 8482A
50 GHz power sensor	HP 8487A [§]
Frequency counter	HP 5342A
Digital multimeter	HP 3478A
Power splitter	HP 11667C
Test and Adjustment Module (TAM)	HP 85629B
Cable, 50 GHz coax	8120-6164
Cable, BNC-to-SMB (2 required)	85680-60093
Cable, BNC-to-BNC (3 required)	HP 10503A
Cable, 36 inch SMA	8120-1578
Cable, HP-IB (8 required)	HP 10833A/B
<p>* 4 megabytes of free memory is required for the adjustment program.</p> <p>[†] The software menu shows the HP 8340 as the synthesized sweeper, but it drives the required HP 83650A (programming language set to “analyzer” mode).</p> <p>[‡] The software menu shows the HP 8566 as the spectrum analyzer, but it will drive the other three spectrum analyzers listed. If an HP 8566 is used, it must be an HP 8566B, not HP 8566A.</p> <p>[§] Must have calibration factors down to 10 MHz; a standard HP 8487A is only calibrated down to 50 MHz.</p>	

Equipment Connections

Computer (Controller) Setup

For HP 9000 model 236 computers, setup instructions are provided in Chapter 1, “Computer Installation,” of the *BASIC Operating Manual*. For HP 9000 model 310, 320, or 350 computers, setup information is provided in the *Configuration Reference Manual* for the Series 300 computers.

HP-IB Cables

All HP-IB controlled test equipment should be connected to the internal HP-IB of the controller (select code 7).

3 Manual Adjustment Procedures

Introduction

This chapter contains information on manual adjustment procedures. Adjustments should be performed after a repair or performance test failure, never perform adjustments as routine maintenance. . For information on which adjustments to perform, refer to [Table 3-1](#).

Information on automated adjustments can be found in Chapter 2 of this service guide. Following is a list of the automated adjustments:

Automated Adjustments

1. Initial Information
2. LO Frequency
3. YTO FM Coil
4. LOMA Adjustments
5. Fast Zero Span
6. 3rd Amp/2nd IF Align
7. Cal Out Adjustment
8. Front End Cal
9. IF Bandpass Poles
10. IF Amplitude
11. DC Log Adjustments
12. Sampling Oscillator

Manual Adjustments

1. High Voltage Power Supply Adjustment 3-9
2. Display Adjustment 3-11
3. IF Bandpass Adjustment 3-17
4. IF Amplitude Adjustments 3-22
5. DC Log Amplifier Adjustments 3-26
6. Sampling Oscillator Adjustment 3-30
7. YTO Adjustment 3-33
8. Calibrator Amplitude Adjustment 3-36
9. 10 MHz Reference Adjustment — OCXO 3-37
10. 10 MHz Reference Adjustment — TCXO (Option 103) 3-40
11. Demodulator Adjustment 3-42
12. External Mixer Bias Adjustment 3-45
13. External Mixer Amplitude Adjustment 3-46
14. Signal ID Oscillator Adjustment (serial prefix 3517A and below) 3-49
15. 16 MHz PLL Adjustment 3-52
16. 600 MHz Reference Adjustment (serial prefix 3406A and above) 3-55

NOTE Before performing any adjustments, allow the spectrum analyzer to warm up for at least 5 minutes.

Safety Considerations

Although this instrument has been designed in accordance with international safety standards, this manual contains information, cautions, and warnings which must be followed to ensure safe operation and to prevent damage to the instrument. Service and adjustments should be performed only by qualified service personnel.

WARNING

- **These servicing instructions are for use by qualified personnel only. To avoid electrical shock, do not perform any servicing unless you are qualified to do so.**
 - **The opening of covers or removal of parts is likely to expose dangerous voltages. Disconnect the product from all voltage sources while it is being opened.**
 - **Adjustments in this section are performed with power supplied to the instrument and protective covers removed. There are voltages at many points in the instrument which can, if contacted, cause personal injury. Be extremely careful. Adjustments should be performed only by trained service personnel.**
 - **Power is still applied to this instrument with the LINE switch in the off position. Before removing or installing any assembly or printed circuit board, remove the line-power cord.**
 - **The power cord is connected to internal capacitors inside that may remain live for 5 seconds after the instrument has been disconnected from its source of supply.**
 - **Use a nonmetallic adjustment tool whenever possible.**
-

Which Adjustments Should Be Performed?

Table 3-1 lists the manual adjustments that should be performed when an assembly is repaired or changed. It is important to perform the adjustments in the order indicated to ensure that the instrument meets its specifications.

Chapter 3a, “Manual Adjustment Procedures: HP 3335A Source Not Available,” provides instructions and procedures for making adjustments when the HP 3335A Synthesizer Level Generator is not available. If the HP 3335A is not available, substitute those procedures for the procedures of the same number and name found in this chapter.

Test Equipment

The equipment required for the manual adjustment procedures is listed in Table 1-5, “Recommended Test Equipment.” Any equipment that satisfies the critical specifications given in the table may be substituted for the preferred test equipment.

Adjustable and Factory-Selected Components

Table 3-2 lists the adjustable components by reference designation and name. For each component, the table provides a description and lists the adjustment number.

Refer to Table 3-3. for a complete list of factory-selected components used in the instrument along with their functions. Factory-selected components are identified with an asterisk on the schematic diagrams.

Adjustment Tools

For adjustments requiring a nonmetallic tuning tool, use fiber tuning tool, HP part number 8710-0033.

Two different tuning tools may be necessary for IF bandpass adjustments, depending on the type of tuning slug used in the slug-tuned inductors. If the tuning slug requires a slotted tuning tool, use HP part number 8710-1010. If the tuning slug requires a forked tuning tool, use HP part number 8710-0772.

Never try to force an adjustment control. This is especially critical when tuning variable capacitors or slug-tuned inductors. Required service accessories, with part numbers, are listed under “Service Kit” in Chapter 1, “General Information.”

Instrument Service Position

Refer to Chapter 4 for information on removing the spectrum analyzer cover assembly and accessing all internal assemblies.

Table 3-1 Related Adjustments

Assembly Changed or Repaired	Perform the Following Related Adjustments in the Order Listed	Adjustment Number	
		Manual	Automated*
A1A1 keyboard	No related adjustment		
A1A2 RPG	No related adjustment		
A2 controller	16 MHz PLL adjustment	15	
	Display adjustment	2	
	If EEROM from old A2 controller could not be used in new A2 or if EEROM must be replaced, also perform the following adjustments:		
	LOMA adjustments		4
	External mixer amplitude adjustment or 3rd amp/2nd IF align [†]	13	6
A3 interface	Front end cal		8
	Display adjustment (fast zero span) [†]	2	5
	Front end cal		8
A4 log amp/cal osc	Display adjustment (fast zero span) [†]	2	5
	Demodulator adjustment	11	
	IF amplitude adjustment [†]	4	10
	DC log amplifier adjustment [†]	5	11
	A5 IF	IF bandpass adjustment [†]	3
IF amplitude adjustment [†]		4	10
A6 power supply	High voltage power supply adjustment	1	
	Display adjustment	2	
A6A1 HV module	High voltage power supply adjustment	1	
	Display adjustment	2	
A7 LOMA	LOMA adjustments		4
	Front end cal <i>(or perform the frequency response performance test in the HP 8560 E-Series Spectrum Analyzer Calibration Guide. The adjustment must be performed if the performance test fails.)</i>		8
A8 low band mixer	Front end cal		8
A9 input attenuator	Front end cal <i>(or perform the frequency response performance test in the HP 8560 E-Series Spectrum Analyzer Calibration Guide. The adjustment must be performed if the performance test fails.)</i>		8

Table 3-1 Related Adjustments (Continued)

Assembly Changed or Repaired	Perform the Following Related Adjustments in the Order Listed	Adjustment Number	
		Manual	Automated*
A10/A12 RYTHM/SBTX	Front end cal		8
A11 YTO	YTO adjustment [‡]	7	
	LO frequency [‡]		2
	YTO FM coil [‡]		3
A13 2nd converter	Front end cal		8
A14 frequency control	Display adjustment (fast zero span) [†]	2	5
	YTO adjustment [‡]	7	
	LO frequency [‡]		2
	YTO FM cal [‡]		3
	Front end cal		8
A15 RF	10 MHz reference adjustment (TCXO, Option 103) or CAL OUT adjustment [†]	15	7
	Calibrator amplitude adjustment or CAL OUT adjustment [†]	8	7
	External mixer bias adjustment	12	
	Sampling oscillator adjustment	6	12
	Signal ID oscillator adjustment	14	
	External mixer amplitude adjustment or 3rd amp/2nd IF align [†]	13	6
	Front end cal		8
A15U100 sampler	Sampling oscillator adjustment [†]	6	12
A17 CRT driver	Display adjustment	2	
A18V1 CRT	Display adjustment	2	
A19 HP-IB	No related adjustment		
A21 OCXO	10 MHz reference adjustment (OCXO)	9	
<p>*If any automated adjustment is required, you must first perform automated adjustment 1, Initial Information.</p> <p>[†] Either the manual or the automated adjustment may be performed.</p> <p>[‡] Perform either the manual “YTO adjustment” (7) or the automated “LO frequency” and “YTO FM coil” adjustments (2 and 3).</p>			

Table 3-2 Adjustable Components

Reference Designator	Adjustment Name	Adjustment Number	Description
A2R152	16 MHz PLL ADJ	22	Adjusts the free-running frequency of the 16 MHz CPU clock
A2R206	DGTL X GAIN	2	Adjusts the horizontal gain in the X line generator.
A2R209	SWEEP OFFSET	2	Adjusts the beginning of the trace to the leftmost vertical graticule line in fast-analog zero-span mode.
A2R215	DGTL Y GAIN	2	Adjusts the vertical gain in the Y line generator.
A2R218	VIDEO OFFSET	2	Adjusts the vertical position in fast-analog zero span to match the digital zero-span input.
A2R262	STOP BLANK	2	Adjusts the blanking at the end of a vector on the display.
A2R263	START BLANK	2	Adjusts the blanking at the start of a vector on the display.
A2R268	VIDEO GAIN	2	Adjusts the vertical gain in fast-analog zero span to match with the digital zero-span input.
A2R271	SWEEP GAIN	2	Adjusts the end of the trace to the rightmost vertical-graticule line in fast-analog zero-span mode.
A4C707	FM DEMOD	16	Adjusts the FM demodulation for a peak response.
A4R445	LIMITER PHASE	5	Adjusts Limiter Phase for peak response.
A4R531	LOG AMP TOS	5	Minimizes error to Top of Screen.
A4R544	LIN FIDELITY BOW	5	Minimizes Linearity Fidelity error.
A4R826	CAL OSC AMPTD	4	Sets calibration oscillator output power (nominally -35 dBm). This power is injected into the IF during the AUTO IF ADJUST routines.
A5L300	LC CTR 1	3	Adjusts center frequency of first stage of LC bandwidth filter to 10.7 MHz.
A5L301	LC CTR 2	3	Adjusts center frequency of second stage of LC bandwidth filter to 10.7 MHz.
A5L700	LC CTR 3	3	Adjusts center frequency of third stage of LC bandwidth filter to 10.7 MHz.
A5L702	LC CTR 4	3	Adjusts center frequency of fourth stage of LC bandwidth filter to 10.7 MHz.
A5R343	15 DB ATT	4	Adjusts the attenuation of the reference 15 dB attenuator for 15 db between minimum and maximum attenuation.

Table 3-2 Adjustable Components (Continued)

Reference Designator	Adjustment Name	Adjustment Number	Description
A5T200	XTAL CTR 1	3	Adjusts center frequency of first stage of crystal bandwidth filter to 10.7 MHz.
A5T202	XTAL CTR 2	3	Adjusts center frequency of second stage of crystal bandwidth filter to 10.7 MHz.
A5T500	XTAL CTR 3	3	Adjusts center frequency of third stage of crystal bandwidth filter to 10.7 MHz.
A5T502	XTAL CTR 4	3	Adjusts center frequency of fourth stage of crystal bandwidth filter to 10.7 MHz.
A6R410	HV ADJ	1	Adjusts the voltage between A6TP405 and A6TP401 to the voltage marked on the A6A1 high voltage module.
A14R42	6.01 GHz	7	Adjusts the main coil tune driver current at a YTO frequency of 6.01 GHz (near the upper YTO frequency limit).
A14R76	FM SPAN	7	Adjusts the FM span accuracy by affecting the sensitivity of the FM coil driver.
A14R93	3.2 GHz	7	Adjusts the main coil fixed driver current at a YTO frequency of 3.2 GHz (near the lower YTO frequency limit).
A15C100	SMPL MATCH	6	Transforms the sampler input impedance to 50 ohms over the 285 to 297.2 MHz range.
A15C210	VCO RANGE	6	Adjusts the VCO tank capacitance so that 21V on the VCO tune line equals 298 MHz VCO frequency.
A15C629	SIG ID	19	Fine adjusts the 298 MHz SIG ID oscillator frequency to optimize its performance.
A15U302	10 MHz ADJ	15	Adjusts frequency of the temperature compensated crystal oscillator (TCXO) to 10 MHz.
A15R561	CAL AMPTD	13	Adjusts amplitude of the 300 MHz calibrator signal to -10.0 dBm.
A15R926	EXT BIAS ZERO	17	Adjusts zero bias point of external mixer bias.
A17R4	Z GAIN	2	Adjusts maximum intensity.
A17R11	CUTOFF	2	Adjusts intensity to turn off blanked lines.
A17R21	Z FOCUS	2	Adjusts focus for lines of different brightness.
A17R26	X FOCUS	2	Adjusts focus at the left and right corners of the display.
A17R34	COARSE FOCUS	2	Adjusts focus at the center of the display.
A17R55	X GAIN	2	Adjusts the horizontal-deflection amplifier gain.

Table 3-2 Adjustable Components (Continued)

Reference Designator	Adjustment Name	Adjustment Number	Description
A17R57	X POSN	2	Adjusts the CRT horizontal position.
A17R75	Y GAIN	2	Adjusts the vertical-deflection amplifier gain.
A17R77	Y POSN	2	Adjusts the CRT vertical position.
A17R90	TRACE ALIGN	2	Adjusts the display axis rotation.
A17R92	DDD	2	Adjusts focus of the center of the display.
A17R93	ASTIG	2	Adjusts for the spot roundness on the CRT display.

Table 3-3. Factory Selected Components

Reference Designator	Adjustment Number	Basis of Selection
A5C204	3	Selected to optimize center frequency of LC tank that loads the crystal.
A5C216	3	Selected to optimize center frequency of LC tank that loads the crystal.
A5C326	3	Selected to optimize LC pole center frequency.
A5C327	3	Selected to optimize LC pole center frequency.
A5C505	3	Selected to optimize center frequency of LC tank that loads the crystal.
A5C516	3	Selected to optimize center frequency of LC tank that loads the crystal.
A5C717	3	Selected to optimize LC pole center frequency.
A5C718	3	Selected to optimize LC pole center frequency.

**3a Manual Adjustment Procedures:
HP 3335A Source Not Available**

What You'll Find in This Chapter

This chapter provides alternative procedures for the adjustment of the spectrum analyzer that do not require the use of the HP 3335A Synthesizer Level Generator. The HP 3335A has been discontinued. Because of the unavailability of the HP 3335A, new adjustments procedures are required that use different signal sources. If the HP 3335A is not available, substitute these procedures for those of the same number found in [Chapter 3, "Manual Adjustment Procedures."](#)

Required Test Equipment

The following table lists the test equipment required to execute the adjustments in this chapter. These adjustments originally required the use of the HP 3335A Synthesizer Level Generator.

Table 3a-1 Recommended Test Equipment

Instrument	Critical Specifications for Equipment Substitution	Recommended Model
Sources		
Synthesized Signal Generator	Frequency range: 250 kHz to 3 GHz Frequency resolution: 1 Hz Attenuator resolution: 0.02 dB Level accuracy: ± 0.5 dB External 10 MHz Ref. Input	HP E4421B or HP E4422B, HP E4432B, HP E4433B
Cables		
Cable, 50 Ω coaxial <i>(four required)</i>	Connectors: BNC (m) Length: ≥ 122 cm (48 in.)	HP 10503A
Cable	Test Cable	85680-60043
Adapters		
Adapter <i>(four required)</i>	Type N (m)-to-BNC (f)	1250-1476
Adapter	Type N (f)-to-2.4 mm (f)	HP 11903B
Adapter	2.4 mm (f) to BNC (f)	1250-2187
Adapter <i>(Option 026 only)</i>	APC-3.5 (f) to APC-3.5 (f)	5061-5311
Adapter <i>(Option 026 only)</i>	APC-3.5 (f) to BNC-3.5 (f)	1250-1200

4a. IF Amplitude Adjustments

The IF amplitude adjustments consist of the cal oscillator amplitude adjustment and the reference 15 dB attenuator adjustment.

Assembly Adjusted

A4 log amp/cal oscillator A5 IF assembly

Related Performance Tests

IF Gain Uncertainty Scale Fidelity

Description

This adjustment sets the output amplitude of the A4 log amp/cal oscillator and the absolute amplitude of the reference 15 dB attenuator.

The output of the A4 log amp/cal oscillator is adjusted so that a -55 dBm signal applied to the 10.7 MHz IF input on the A5 IF assembly (A5J3) causes a displayed signal of -60 dBm. The effect of this adjustment is visible only after the **ADJ CURR IF STATE** sequence is complete. **ADJ CURR IF STATE** causes the IF gain adjustment to use the “new” output amplitude from the A4 log amp/cal oscillator.

This procedure also sets the attenuator of the reference 15 dB attenuator so that a source amplitude change of 50 dB combined with a spectrum analyzer reference level change of 50 dB displays an amplitude difference of 50 dB.

Figure 3a-1 IF Amplitude Adjustment Setup

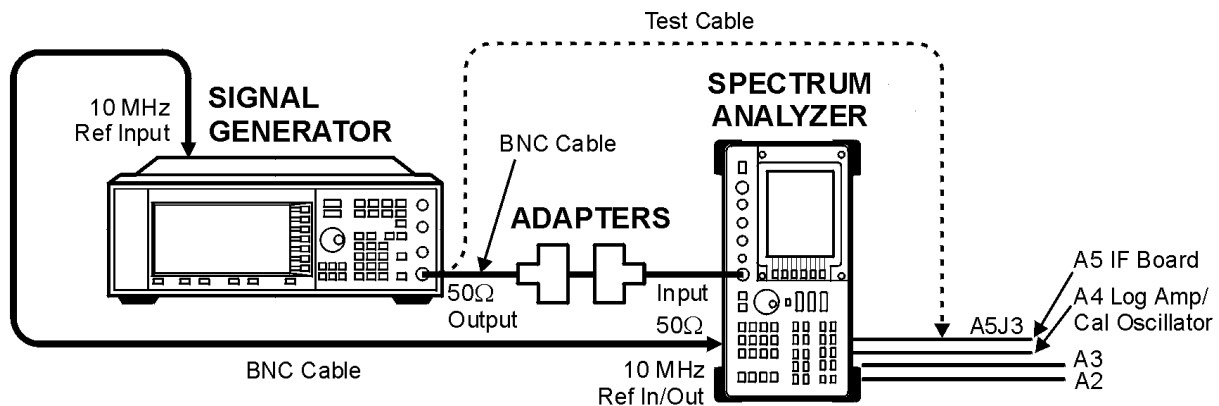

hj11e

Equipment

Signal Generator HP E4421B

Adapters

Type N (m) to BNC (f) 1250-1476

Type N (f) to 2.4 mm (f) HP 11903B

Cables

BNC, 122 cm (48 in) HP 10503A

Test cable 85680-60093

Figure 3a-2 IF Amplitude Adjustment Locations

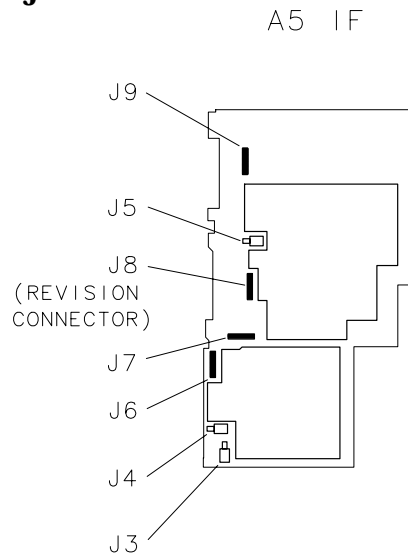

sj115c

NOTE The 15 dB reference attenuator adjustment is preset at the factory and need not be done if the entire A5 IF assembly is replaced.

4a. IF Amplitude Adjustments

Procedure

1. Press **LINE** to turn the spectrum analyzer off. Remove the spectrum analyzer cover and place the spectrum analyzer in the service position as illustrated in [Figure 3a-1](#).
2. Disconnect W29, violet coax cable, from A5J3. Connect the test cable between A5J3 and the RF output of the HP E4421B. Press **LINE** to turn the spectrum analyzer on.
3. Set the spectrum analyzer controls as follows:

Center Frequency 10.7 MHz
 Span 200 kHz
 Reference Level -60 dBm
 Attenuator 0 dB
 dB/division 1 dB/DIV
 Resolution bandwidth 300 kHz
 Video bandwidth 100 Hz

4. On the spectrum analyzer, press **MKR**, **CAL**, and **IF ADJ ON OFF** so **OFF** is underlined.
5. Set the HP E4421B controls as follows:

Frequency 10.7 MHz
 Amplitude -55 dBm
 Mod On/Off. Off

6. Note the marker value. Ideally it should read $-60 \text{ dBm} \pm 0.1 \text{ dB}$.
7. If the marker reads less than -60.1 dBm , rotate A4R826 CAL OSC AMPTD one-third turn clockwise for every 0.1 dB less than -60 dBm . See [Figure 3a-2](#) for the location of A4R826. A change in the displayed amplitude will not be seen until **ADJ CURR IF STATE** is pressed.
8. If the marker reads greater than -59.9 dBm , rotate A4R826 CAL OSC AMPTD one-third turn counter clockwise for every 0.1 dB greater than -60 dBm . See [Figure 3a-2](#) for the location of A4R826. A change in the displayed amplitude will not be seen until **ADJ CURR IF STATE** is pressed.

NOTE If A4R826 has inadequate range, refer to “Inadequate CAL OSC AMPTD Range” in Chapter 9.

9. On the spectrum analyzer, press **ADJ CURR IF STATE**. After allowing the analyzer time to complete the adjustments, the displayed amplitude and marker reading should change.
10. Repeat [step 7](#) and [step 9](#) until the marker reads $-60 \text{ dBm} \pm 0.1 \text{ dB}$.
11. Disconnect the test cable from A5J3 and reconnect W29 to A5J3.

A5 Reference Attenuator Adjustment

1. Set the spectrum analyzer reference level to -60 dBm. If markers are displayed, press **MKR** and **MARKERS OFF**.
2. Set the HP E4421B **AMPLITUDE** to -60 dBm.
3. Connect a BNC cable between the RF output of the HP E4421B and the spectrum analyzer INPUT 50Ω
4. On the spectrum analyzer, press **CAL** and **REF LVL ADJ**. Use the front panel knob or step keys to place the peak of the displayed signal 3 dB to 5 dB below the reference level.
5. On the spectrum analyzer, press **PEAK SEARCH** and **MARKER DELTA**. Set the spectrum analyzer reference level to -10 dBm.
6. Change the HP 4421B **Amplitude** to -10 dBm.
7. On the spectrum analyzer, press **CAL**.
8. Note the Δ MKR amplitude. Ideally, it should read 50.00 dB ± 0.1 dB.
9. If the Δ MKR amplitude is less than 49.9 dB, rotate A5R343 15 dB ATTEN one-half turn counterclockwise for each 0.1 dB less than 50.00 dB. Do not adjust A5R343 more than five turns before continuing with the next step.
10. If the Δ MKR amplitude is greater than 50.1 dB, rotate A5R343 15 dB ATTEN one-half turn clockwise for each 0.1 dB greater than 50.00 dB. Do not adjust A5R343 more than five turns before continuing with the next step.
11. On the spectrum analyzer, press **ADJ CURR IF STATE**. Note the Δ MKR amplitude reading.
12. Repeat [step 1](#) through [step 11](#) until the Δ MKR amplitude reading is 50.00 dB ± 0.1 dB.

4a. IF Amplitude Adjustments

A5 Adjustment Verification

1. On the spectrum analyzer, disconnect W29 from A5J3. Connect the test cable between A5J3 and the RF output of the HP E4421B.
2. Set the spectrum analyzer reference level to -10 dBm.
3. Set the HP E4421B **Amplitude** to -5 dBm.
4. On the spectrum analyzer, press **MKR** and **MARKER NORMAL**.
5. The **MARKER** amplitude should read -10 dBm ± 0.13 dB. If the reading is outside of this range, repeat [step 4 of "Procedure," on page 6](#) through ["A5 Reference Attenuator Adjustment" step 12](#).
6. On the spectrum analyzer, reconnect W29 to A5J3. Press **PRESET** and set the controls as follows:
Center frequency 300 MHz
Span 0 Hz
Reference level -10 dBm
Resolution bandwidth 300 kHz
7. Connect a BNC cable between the HP 8563E **CAL OUTPUT** and **INPUT 50 Ω**
8. On the spectrum analyzer, press **MKR CAL** and **REF LVL ADJ**.
9. Use the knob or step keys to adjust the **REF LEVEL CAL** setting until the **MKR** reads -10.00 dBm ± 0.1 dB.
10. On the spectrum analyzer, press **STORE REF LVL**.

5a. DC Log Amplifier Adjustments

There are three DC log adjustments; limiter phase, linear fidelity, and log fidelity.

Assembly Adjusted

A4 log amp/cal oscillator

Related Performance Tests

IF Gain Uncertainty Scale Fidelity

Description

These three adjustment need only be done under the following conditions:

Limiter phase Only if a repair is made to blocks F, G, H, I, or J.

Linear fidelity Only if a repair is made to blocks C, D, F, G, H, I, J, K, O, IF gain accuracy, RBW switching, or log fidelity.

Log fidelity Only if a repair is made to blocks D, F, H, K, IF gain accuracy, RBW switching, or log fidelity.

If multiple adjustments are required they should be done in the following order:

1. Limiter Phase
2. Linear Fidelity
3. Log Fidelity

Figure 3a-3 DC Log Adjustment Setup

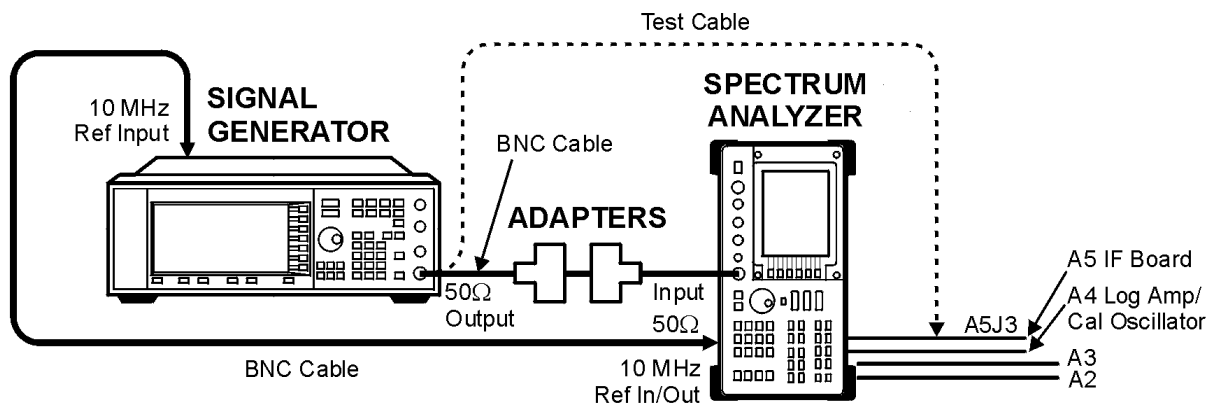

hj11e

Equipment

Signal GeneratorHP E4421B

Adapters

Type N (m) to BNC (f) 1250-1476

Type N (f) to 2.4 mm (f) HP 11903B

Cables

BNC, 122 cm (48 in) HP 10503A

Test cable 85680-60093

Figure 3a-4 DC Log Adjustment Locations

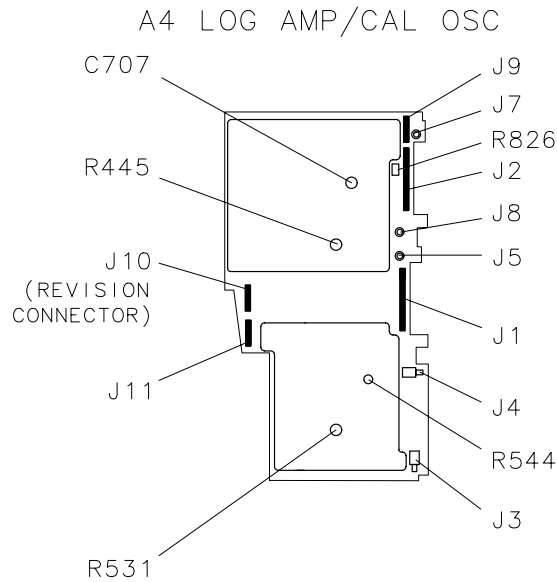

sj116c

NOTE Adjustments should be made with all of the shields on and only after allowing at least a 20 minute warmup.

A4 Limiter Phase Adjustment

1. Press **LINE** to turn the spectrum analyzer off. Remove the spectrum analyzer cover and place the spectrum analyzer in the service position as illustrated in [Figure 3a-3](#). See [Figure 3a-4](#) for adjustment location.
2. Connect the HP E4421B RF output to the spectrum analyzer 50 Ω input. Press **LINE** to turn the spectrum analyzer on.
3. Set the spectrum analyzer controls as follows:

Center frequency	15 MHz
Span	0 Hz
Reference level	-10 dBm
dB/division	1 dB/DIV
Resolution bandwidth	300 kHz
IF ADJ	OFF
4. Set up an HP E4421B as follows:

Frequency	15 MHz
Amplitude	-18 dBm
Mod On/Off	Off
5. On the spectrum analyzer, press **CAL** and **ADJ CURR IF STATE**, wait for the analyzer to complete adjustments then press **MKR**.
6. Adjust A4R445 for maximum on-screen amplitude. Refer to [Figure 3a-4](#) for the location of A4R445.

A4 Linear Fidelity Adjustment

1. Press **LINE** to turn the spectrum analyzer off. Remove the spectrum analyzer cover and place the spectrum analyzer in the service position as illustrated in [Figure 3a-3](#). See [Figure 3a-4](#) for adjustment location.
2. Connect the HP E4421B RF output to the spectrum analyzer 50Ω input. Press **LINE** to turn the spectrum analyzer on.
3. On the spectrum analyzer, press **PRESET AMPLITUDE**, **LINEAR**, **MORE 1 of 3**, **AMPTD UNITS**, **dBm**, **CAL**, and **IF ADJ ON OFF (OFF)**.
4. Set the spectrum analyzer controls as follows:
Center frequency 15 MHz
Span 5 MHz
Resolution bandwidth 300 kHz
Reference level -10 dBm
5. Set up an HP E4421B as follows:
Frequency 15 MHz
Amplitude -10 dBm
Mod On/Off Off
6. On the spectrum analyzer, press **PEAK SEARCH** and **MARKER DELTA**.
7. Reduce the HP E4421B input power to -58 dBm.
8. If the delta marker amplitude reads -40 dB ±2 dB, no adjustment is necessary.
9. If the signal is lower on the screen than expected (delta marker amplitude reads less than -42dB) then adjust A4R544 (see [Figure 3a-4](#)) for an even lower level and press **CAL** and **ADJ CURR IF STATE**. Allow sufficient time for the analyzer to complete the adjustment.
10. If the signal is higher on the screen than expected (delta marker amplitude reads greater than -38 dB) then adjust A4R544 for an even higher level signal and press **CAL** and **ADJ CURR IF STATE**. Allow sufficient time for the analyzer to complete the adjustment.
11. Repeat [step 7](#) through [step 10](#).

A4 LOG Fidelity Adjustment

1. Press **LINE** to turn the spectrum analyzer off. Remove the spectrum analyzer cover and place the spectrum analyzer in the service position as illustrated in [Figure 3a-3](#). See [Figure 3a-4](#) for adjustment location.
2. Connect the HP E4421B RF output to the spectrum analyzer 50Ω input. Press **LINE** to turn the spectrum analyzer on.
3. On the spectrum analyzer, press **PRESET**, **CAL**, **IF ADJ ON OFF (OFF)**, and **ADJ CURR IF STATE**.
4. Set the spectrum analyzer controls as follows:

Center frequency 15 MHz
Span. 0 MHz
Resolution bandwidth. 300 kHz
Reference level -10 dBm

5. Set up an HP E4421B as follows:

Frequency 15 MHz
Amplitude -10 dBm
Mod On/Off Off

6. On the spectrum analyzer, press **MKR** and **MARKER DELTA**.
7. Decrease the HP E4421B power to -26 dBm.
8. Calculate the error:

$$\text{Error} = \text{delta marker reading} - 16 \text{ dB}$$

9. If the error is less than ±0.2 dB, no adjustment is necessary.
10. Set the HP E4421B power to -10 dBm.
11. Adjust A4R531 (see [Figure 3a-4](#)) to read two times the error. For example, if the calculated error is +0.75 dB, adjust A4R531 for a delta marker amplitude reading of +1.5 dB. Press **CAL** and **ADJ CURR IF STATE**.
12. Repeat [step 7](#) through [step 11](#).

Index

A

- A4 limiter phase adjustment,
[3a-11](#)
- A4 linear fidelity adjustment,
[3a-12](#)
- A4 log fidelity adjustment, [3a-13](#)
- adjustment
 - adjustable components table,
[3-5](#)
 - factory selected components, [3-5](#)
 - related adjustments table, [3-4](#)
 - safety considerations, [3-3](#)
 - tools, [3-4](#)
- adjustment procedures, [3-2](#)
 - cal oscillator amplitude, [3a-4](#)
 - DC log amplifiers, [3a-9](#)
 - IF amplitude, [3a-4](#)
- adjustments
 - recommended test equipment,
[3a-3](#)

C

- components
 - adjustable components table,
[3-5](#)

D

- DC log amplifier adjustments,
[3a-9](#)

I

- IF amplitude adjustments, [3a-4](#)
- implementation instructions, [1-3](#)
- introduction, [1-2](#)

L

- limiter phase adjustment, [3a-11](#)
- linear fidelity adjustment, [3a-12](#)
- log fidelity adjustment, [3a-13](#)

T

- test equipment list, [3a-3](#)
- test equipment, automated
 - adjustments, [2-18](#)
- tools
 - adjustment, [3-4](#)

U

- using the supplement, [1-1](#)